

STYLISTIC ^{LT}
C-500

User's Guide

Guide de l'utilisateur

Benutzerhandbuch

Manual del Usuario

Manuale Utente

FUJITSU

STYLISTIC ^{LT}
C-500

User's Guide

Guide de l'utilisateur

Benutzerhandbuch

Manual del Usuario

Manuale Utente

FUJITSU

Fujitsu PC Corp. has made every effort to ensure the accuracy and completeness of this document; however, because ongoing development efforts are made to continually improve the capabilities of our products, we cannot guarantee the accuracy of the contents of this document. We disclaim liability for errors, omissions, or future changes herein.

Fujitsu and the Fujitsu logo are registered trademarks of Fujitsu Limited.

Stylistic LT C-500 is a trademark of Fujitsu PC Corp.

IBM, IBM PC AT, and IBM PS/2 are registered trademarks of IBM Corporation.

Kensington and MicroSaver are registered trademarks of the Kensington Technology Group.

PCMCIA and CardBus are registered trademarks of the Personal Computer Memory Card International Association.

Intel and Pentium are registered trademarks of Intel Corporation.

Microsoft is a registered trademark of Microsoft Corporation. Windows 98 and Windows 2000 are trademarks of Microsoft Corporation.

All other products are trademarks or registered trademarks of their respective companies.

Copyright 2000 - Fujitsu PC Corporation. All rights reserved. No part of this publication may be copied, reproduced, or translated, without the prior written consent of Fujitsu PC Corp. No part of this publication may be stored or transmitted in any electronic form without the prior consent of Fujitsu PC Corp.

Stylistic LT C-500 User's Guide - 58-0733-00B



DECLARATION OF CONFORMITY according to FCC Part 15

Responsible Party Name:	Fujitsu PC Corp.
Address:	5200 Patrick Henry Drive Santa Clara, CA 95054
Telephone:	408-982-9500
Declares that product:	Model: Stylistic LT C-500, FMW4303TS Complies with Part 15 of the FCC Rules

This device complies with Part 15 of the FCC rules. Operation is subject to the following two conditions: (1) This device may not cause harmful interference, and (2) This device must accept any interference received, including interference that may cause undesired operation.

For more detailed information about the FCC rules and their applicability to the Stylistic LT C-500 pen tablet, refer to Appendix C of this document.

Table of Contents

Chapter 1

Getting Started

In-box Items for the Stylistic LT C-500 Pen Tablet	1
Optional Accessories	2
Stylistic LT C-500 Pen Tablet Features	3
Status Display	6
Connectors and Peripheral Interfaces	9

Chapter 2

Using the Stylistic LT C-500 Pen Tablet

System States	13
Powering Up the Pen Tablet	15
Shutting Down the System	16
Suspending System Operation	16
Resuming System Operation	18
Using Hotpads	20
Using the Pen	23
Calibrating the pen	23
Replacing the Pen	25
Using Hovering Mode	25
Charging the Battery Pack	25
Removing and Installing the Battery Pack	26
Tips for Conserving Battery Power	27
Modem Connection	29
PC Card Slot	29
Compact Flash Slot	30

Chapter 3

Care and Maintenance

Protecting the Display Screen	31
Storing the Stylistic LT C-500 Pen Tablet	32
Avoiding Overheating	33
Cleaning the Display Screen	33
Troubleshooting	34
System Will Not Resume Operation	34
Display Screen Is Blank or Difficult to Read	34
Cursor Is Not Tracking Pen	34
Infrared Data Transfer Is Not Working	35
Pen Tablet Is Not Responding to the Pen	35
Audio Volume Too Low	35
Configuring Peripherals Interfaces	36

Appendix A	
Stylistic LT C-500 Hardware Specifications	
Stylistic LT C-500 Specifications	37
Appendix B	
Digitizer Technology Notice	
Additional Display Information	41
Appendix C	
Agency Notices	
FCC Notices	43
Notice to Users of Radios and Television.....	44
Notice to Users of the US Telephone Network.....	44
DOC (Industry Canada) Compliance Notices	46
Notice to Users of Radios and Television.....	46
Notice to Users of the Canadian Telephone Network.....	46
Avis Aux Utilisateurs Du Réseau Téléphonique Canadien.....	47

Chapter 1

Getting Started

The Stylistic LT C-500™ pen tablet is a high-performance, pen-based computer that is designed to support Microsoft Windows 98 or Windows 2000. This chapter provides an overview of the Stylistic LT C-500 pen tablet and its features.

In-box Items for the Stylistic LT C-500 Pen Tablet

The following items are included with the Stylistic LT C-500 pen tablet:

- Stylistic LT C-500 pen
- Stylistic LT C-500 battery pack (shipped installed in the Stylistic LT C-500 pen tablet)
- AC adapter (with country-specific power cord)
- Screen protectors (quantity: 2)
- Hard disk drive with operating system (shipped installed in the pen tablet)
- Combination LAN/56 Kbps* internal modem (V.90) module**: 53 Kbps receive/33.6 Kbps send/14.4 Kbps fax
- Certificate of Authenticity for operating system software
- Stylistic LT C-500 Warranty Card

* The 56 Kbps rate is nominal; due to U.S. FCC restrictions, actual rates are limited to 53 Kbps.

**The LAN/modem module is certified only in the following countries:
United States, Canada, Japan, Belgium, Denmark, Finland, France, Germany, The Netherlands, Italy, Norway, Sweden, Switzerland, United Kingdom, Austria, Portugal, Ireland, Spain, and Greece.

Optional Accessories

The following optional accessories can be used with the Stylistic LT C-500 pen tablet. Refer to the instructions provided with these accessories for details on their use.

Peripheral/Accessory	Fujitsu Part Number
Stylistic LT C-500 mini-dock	FMW43PR1
Stylistic LT C-500 charge-only cradle	FMW29CR1
Stylistic LT C-500 portfolio case	FMWCC45
Stylistic LT C-500 slipcase	FMWCC44
Stylistic LT C-500 Holster	FMWCC34
External floppy disk drive	FMWFD2
Mobile USB keyboard	(US) FMWKB5A (UK) FMWKB5B (FR) FMWKB5F (GR) FMWKB5D (IT) FMWKB5E
Infrared keyboard	(US) FMWKB4A (UK) FMWKB4B (FR) FMWKB4F (GR) FMWKB4D
Auto adapter	FMWCB2
VGA Out Adapter	FMW43VA1
Compact Desk Stand	FMWDS4
AC adapter	(US) FPCAC14A (UK) FPCAC14B (Euro) FPCAC14C
Stylistic LT C-500 battery pack (spare, 6-cell)	FMW43BP2
Stylistic external battery charger	FMW51BC1
Screen protectors (package of 12)	FMWSP11
Stylistic pens (package of 5)	FMW29PN1

Stylistic LT C-500 Pen Tablet Features

Features and controls that you use to operate the Stylistic LT C-500 pen tablet are described briefly below and illustrated in Figures 1-1 and 1-2. Details on using these features and controls are provided later in this manual.

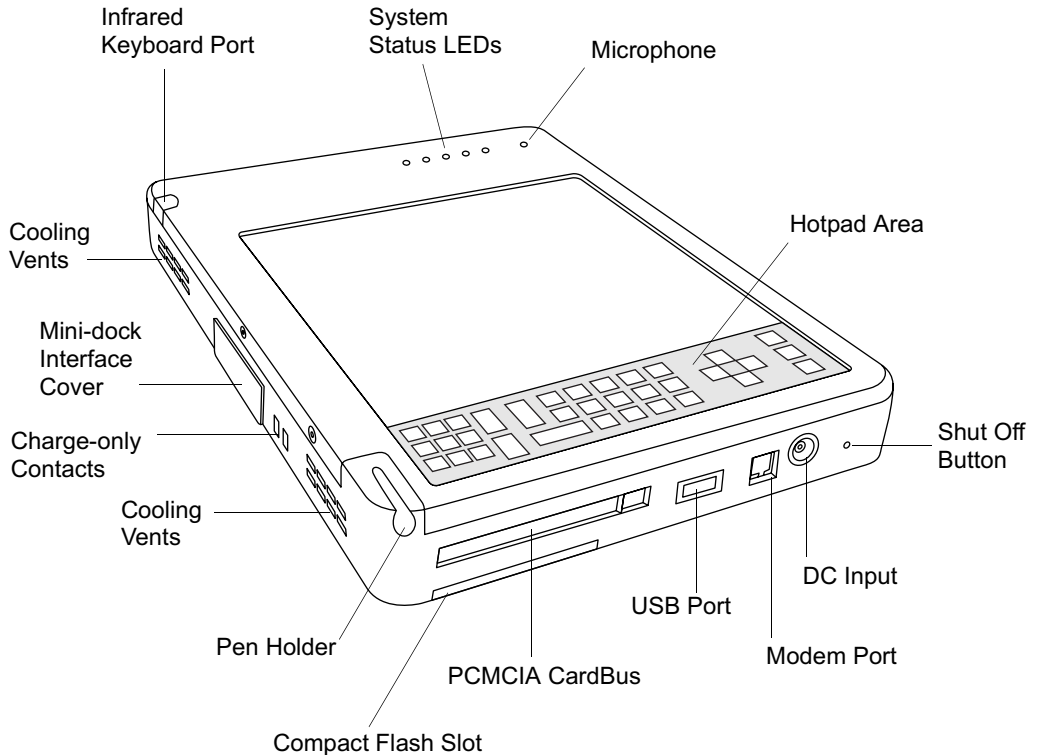

Figure 1-1 Stylistic LT C-500 Pen Tablet Features (Front View)

Front / Bottom / Right Features:

- **Infrared keyboard port:** The infrared port wraps around the front and bottom of the display, and is used for communicating with a proprietary infrared keyboard.[†]
- **System status LEDs:** Indicate the operational status of the pen tablet and hard disk drive, the charge level of the battery, and the status of the hovering mode.

- **Microphone:** Allows you to record sound files, such as voice memos.
- **Hotpads:** Contains several keys that allow you to change settings for the display brightness and speaker volume, and to allow emulation of a right mouse button. The hotpads also let you select hovering mode and to Save-to-Disk by tapping with the pen.
- **Shut Off button:** Turns off the pen tablet in the event of system difficulty.
- **DC input connector:** Allows you to connect the AC adapter or auto adapter.[†]
- **Modem port:** Allows you to connect a standard RJ-11 connector to the pen tablet's internal 56 Kbps modem.

Note: The port for the LAN element of the internal LAN/Modem module is available on the optional mini-dock.[†]

- **USB port A:** Allows you to connect Universal Serial Bus-compliant devices to the pen tablet. USB port B is located on the optional mini-dock.[†]
- **PCMCIA CardBus:** Allows you to install PC Cards in the system.[†]
- **Pen:** The main pointing device that you use to execute programs and enter data. A pen holder is built into the pen tablet to store the pen when not in use.
- **Cooling vents:** Provides secondary cooling for processor. (These vents should not be obstructed.)
- **Charging contacts:** Allows you to charge the battery pack and supply power to the Stylistic in an optional mini-dock[†] or charge-only cradle.[†]
- **Mini-dock interface:** Allows you to install the Stylistic in an optional mini-dock[†] for enhanced connectivity

[†] These peripherals and accessories are sold separately.

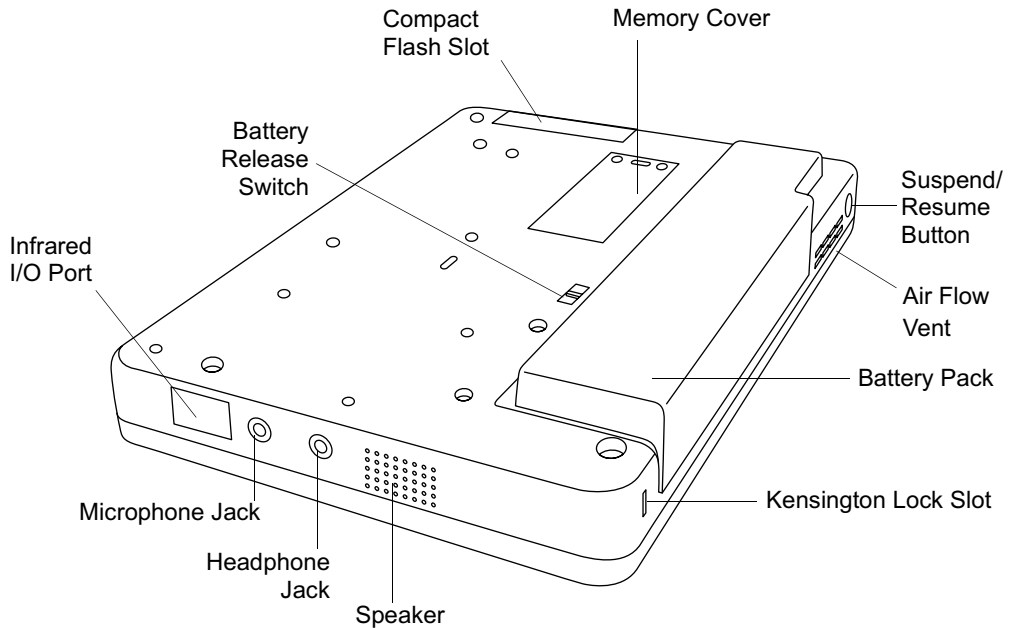

Figure 1-2 Stylistic LT C-500 Pen Tablet Features (Rear View)

Rear / Top / Left Features:

- **IrDA/FIR port:** Provides an infrared interface for communication with devices compliant with IrDA Standard Revision 1.1.
- **Battery release switch:** Used to release the removable battery pack.
- **Compact flash slot:** Used to accommodate a compact flash card.
- **Memory cover:** Removable cover over the RAM chips.
- **Suspend/Resume button:** Allows you to suspend and resume pen tablet operation in order to optimize battery life.
- **Removable battery pack:** Can be removed and charged in an optional external charger.[†]
- **Kensington™ lock slot:** Allows you to attach a Kensington MicroSaver™-compatible security cable.[†]

- **Speaker:** Allows you to play back audio files without external hardware.
- **Headphone Jack:** Allows you to connect a set of headphones.
- **Microphone Jack:** Allows you to connect an external microphone.
- **Air flow vents:** Provides secondary cooling for processor. (Do not obstruct the vents.)

† These peripherals and accessories are sold separately.

Status Display

Icons appear in the Status display indicating the status of system functions such as system power and battery charge level. The location of icons in the Status display is shown in Figure 1-3.

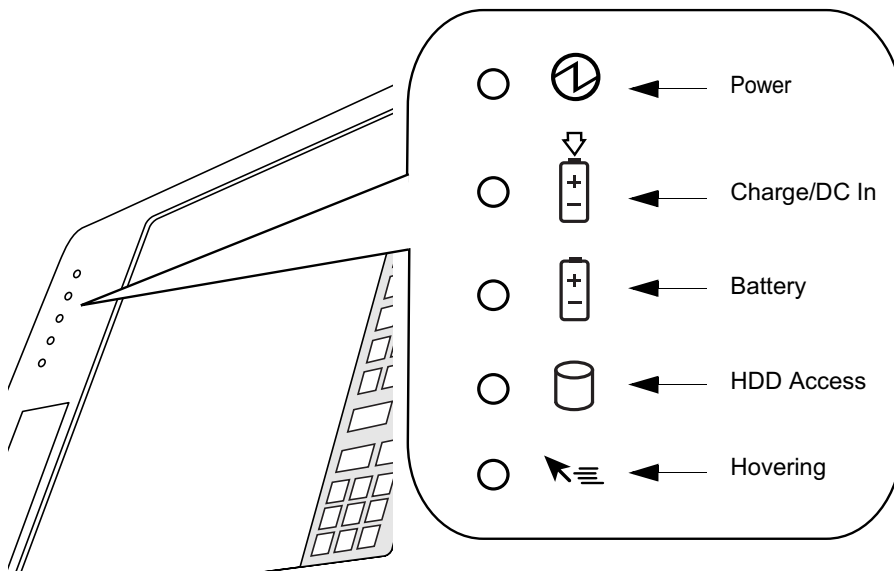

Figure 1-3 Status Display Icons

Table 1-1 explains how individual icons are displayed, and describes what the variations of that display indicate. (If an icon is not displayed, it indicates that the related system function is off or inactive.)

Note: In the following table, a “blinking” LED flashes at the rate of once per second; an LED that is “blinking, slow” flashes at the rate of one second on, five seconds off.

Table 1-1 System Status Indicators





Icon	Mode/State	LED State	Remarks
Power 	<ul style="list-style-type: none"> • On State • Idle Mode 	Green (continuous)	
	<ul style="list-style-type: none"> • Suspend-to-RAM 	Green (blinking)	
	<ul style="list-style-type: none"> • Off State • Save-to-Disk 	Off	
Charge/ DC Input 	<ul style="list-style-type: none"> • On State • Idle Mode • Suspend-to-RAM • Save-to-Disk • Off State 	Green	<ul style="list-style-type: none"> • AC adapter and battery pack are available and system is not charging (battery fully charged). • AC adapter is available but battery pack is not present.
		Amber	AC adapter and battery pack are available and system is charging.
		Amber (blinking)	AC adapter and battery pack are available and waiting to charge (battery pack is out of thermal range).
		Off	AC adapter is not available.

Table 1-1 System Status Indicators

Battery 	<ul style="list-style-type: none"> • On State • Idle Mode • Suspend-to-RAM with AC adapter • Save-to-Disk, with AC adapter • Off State 	Green (continuous)	Battery pack charge is between 100%-50%
		Amber (continuous)	Battery pack charge is between 49%-13%
		Red (continuous)	Battery pack charge is between 12%-0%
		Red (blinking)	There is a battery error.
		Off	Battery pack is not installed.
	<ul style="list-style-type: none"> • Suspend-to-RAM, without AC adapter 	Green (blinking slow)	Battery pack charge is between 100%-50%.
		Amber (blinking slow)	Battery pack charge is between 49%-13%.
		Red (blinking slow)	Battery pack charge is between 12%-0%.
	<ul style="list-style-type: none"> • Save-to-Disk, without AC adapter • Off State 	Off	If battery is inserted during power off, LED blinks amber for 4 seconds to detect battery. Battery status is displayed for 5 seconds after that.
	HDD Access 	<ul style="list-style-type: none"> • On State • Idle Mode 	Green
<ul style="list-style-type: none"> • Suspend-to-RAM • Save-to-Disk • Off State 		Off	Hard disk drive is not being accessed.
Hovering 	<ul style="list-style-type: none"> • On State (Hovering enabled) 	Green	Hovering mode is enabled
	<ul style="list-style-type: none"> • On State (Hovering disabled) 	Off	Hovering mode is disabled.
	<ul style="list-style-type: none"> • Suspend-to-RAM • Save-to-Disk • Off State 	Off	Not available when system is in Suspend-to-RAM, Save-to-Disk, or Off state.

Connectors and Peripheral Interfaces

Connectors and peripheral interfaces on the Stylistic LT C-500 pen tablet allow you to connect a variety of devices. Specific interface locations are illustrated in Figure 1-4, Figure 1-5, and Figure 1-6.

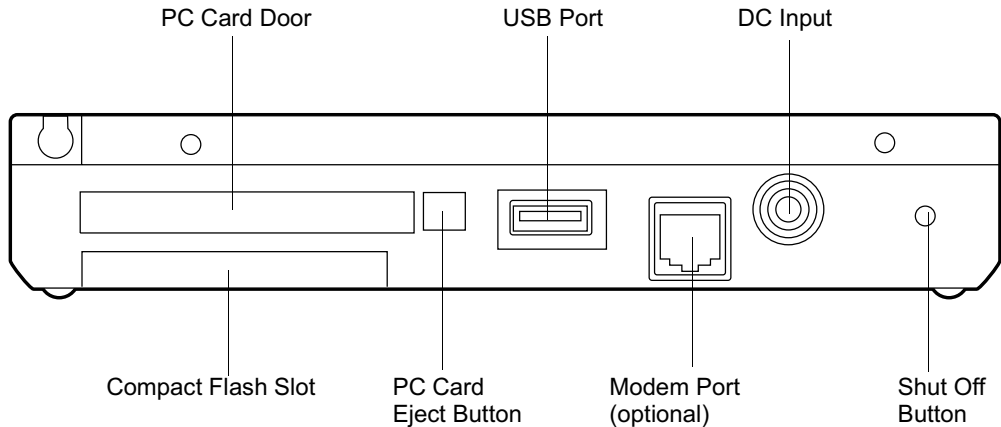

Figure 1-4 Right-Side Connectors and Interfaces

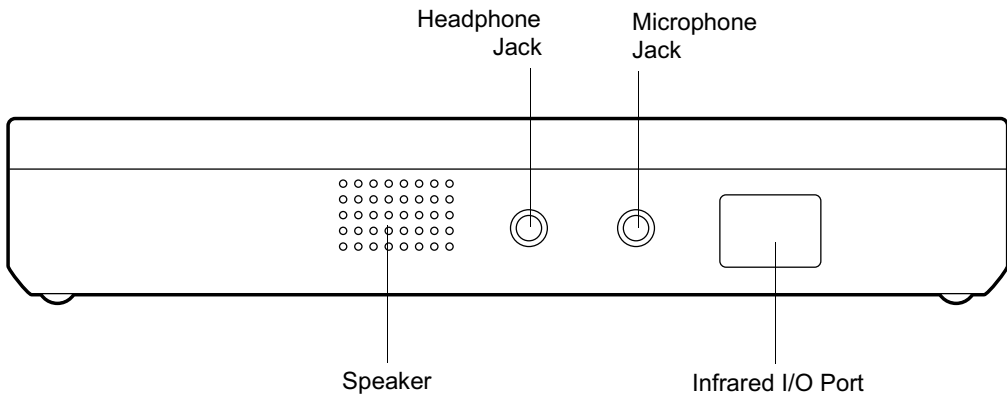

Figure 1-5 Left-Side Connectors and Interfaces

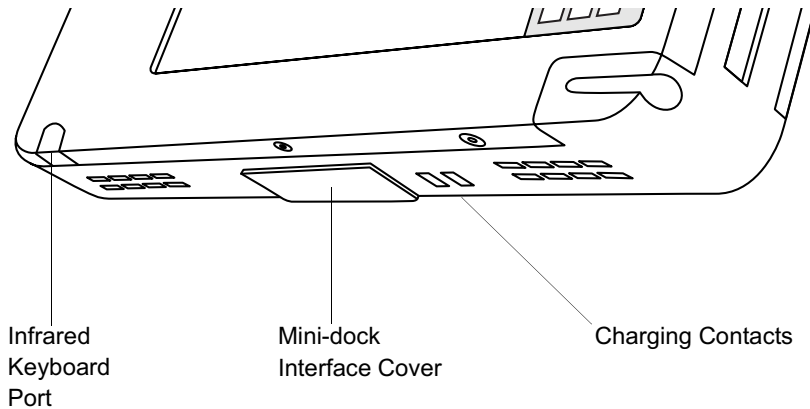

Figure 1-6 Bottom Connectors and Interfaces

Table 1-2 provides a description of each peripheral connector on the Stylistic LT C-500 pen tablet. Each of the illustrated icons is printed on the pen tablet case.

Table 1-2 Peripheral Connectors/Interfaces













Connector/ Peripheral	Fig. Ref.	Pen Tablet Icon	Purpose
DC input connector	1-4		Connect an external power source such as the AC adapter or auto adapter.
USB Port	1-4		Connect Universal Serial Bus-compliant devices to the pen tablet. USB (B) port is located on the optional Stylistic LT C-500 mini-dock.
PCMCIA CardBus slot	1-4		Install a Type II PC Card.
Microphone jack	1-5		Connect an external microphone. The internal microphone is disabled when you plug in an external microphone.
Headphone jack	1-5		Connect stereo headphones or powered external speakers. The internal speaker is disabled when you plug in external headphones or speakers.

Table 1-2 Peripheral Connectors/Interfaces

Connector/ Peripheral	Fig. Ref.	Pen Tablet Icon	Purpose
IrDA/FIR port	1-5		An infrared transceiver built into the pen tablet allows you to communicate with other devices that are compliant with the IrDA Standard Rev. 1.1. Effective range for infrared communication is about 3 feet, and within 15 degrees off of center. A clear line-of-sight path must exist between the IrDA port on the pen tablet and the IrDA transceiver on the other device.
Modem	1-4		Connect a telephone line to the optional internal modem using a standard RJ-11 telephone plug.
Charging Contacts	1-6		Install the pen tablet in an approved docking device. The contacts provide DC input.
Mini-dock port†	1-6		Connect the Stylistic LT C-500 mini-dock or other approved docking device. Refer to the documentation accompanying the docking device for more information.
Infrared keyboard port	1-6		An infrared receiver built into the pen tablet allows you to communicate with a wireless infrared keyboard. The keyboard infrared port works optimally between 10 to 30 cm (approximately 4 in. to 12 in.) from the keyboard infrared port, located on the bottom edge of the pen tablet. Ensure that there is a clear line-of-sight path between the infrared receiver on the pen tablet and the infrared transmitter on the keyboard.
Compact Flash Slot	1-4	CF CARD	Install a compact flash card to expand system memory.
† Remove the mini-dock interface cover to access this port.			

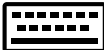
In addition to the connector and interface icons, there are a number of icons that illustrate component orientation and buttons. These icons are illustrated in Table 1-3.

Table 1-3 Additional System Icons

Icon Description	Icon Illustration	Purpose
Battery		Indicates the location of the removable battery cover.
Battery Release Switch		Indicates the battery release button.
Suspend/Resume Button		Indicates the Suspend/Resume button.
Shut Off Button	No icon	Powers down the system in the event of system difficulty.

Chapter 2

Using the Stylistic LT C-500 Pen Tablet

This chapter covers the fundamental concepts, basic system operation and use, and system functions of the Stylistic LT C-500 pen tablet. You should familiarize yourself with this information before you attempt to operate the system.

System States

Before you begin using the Stylistic LT C-500 pen tablet, review the different system states (or modes) that the pen tablet can use. Being familiar with these system states will help you to determine whether it is appropriate to turn on, resume, suspend, or shut down the system when you begin a new session or end your current session. System behavior for each system state is described briefly in the following, with each system state listed in decreasing order of power usage:

- **On state**
The system is running and the display screen is on.
- **Idle state**
Some system functions are regulated or turned off to conserve power. The display screen may be turned off. The system returns to the On state when pen activity or other input is detected.
- **Suspend-to-RAM mode**
System operation is suspended. Most system functions are turned off to conserve power. Power to memory is on, maintaining data in programs that were running before system operation was suspended. The system does not respond to the pen or other input when in Suspend-to-RAM mode. Refer to the “Resuming System Operation” section later in this chapter for information on returning the system to the On state.
- **Save-to-Disk mode**
System operation is suspended. All system functions are turned off to conserve power. Active data in programs that were running before suspending system operation is stored on the hard disk drive. The system does not respond to the pen or other input. Refer to the “Resuming System Operation” section later in this chapter for information on returning the system to the On state.

- **Off state**

All system functions are turned off to conserve power. The system does not respond to the pen or other input. The system boots at the next system power-on.

Note: The system consumes the same amount of power whether it is in Save-to-Disk mode or the Off state.

Your system may be configured to enter some of these states automatically after a period of inactivity to conserve battery power.

When you use the Stylistic LT C-500 pen tablet, you can change the current system state in a number of ways, depending on which state the system is in. To determine the current system state, observe the Power icon in the Status display. Table 2-1 gives the different system states represented by the Power icon and describes how you can change the system state from the current state.

Table 2-1 Changing System States

 Power Icon Appearance	Current State	To Change State *
Power icon displayed continuously	On State or Idle State	To enter the Off state, shut down the system using the Start menu on your system.
		To enter Suspend-to-RAM or Save-to-Disk [†] state, suspend system operation using either a hardware or software suspend.
Power icon blinking	Suspend-to-RAM [†] or Standby	To enter the On state, resume system operation by pressing the Suspend/Resume button.
		To enter the Off state, resume system by pressing the Suspend/Resume button, then shut down your system.
Power icon not displayed	Off State or Save-to-Disk [†]	To enter the On state, start your system, or resume system operation by pressing the Suspend/Resume button.

* Information in Table 2-1 is supplied to help you understand which system states your system can enter from the current system state. Refer to the procedures on starting the system, shutting down the system, suspending system operation, and resuming system operation given later in this chapter.

[†] Your system may be configured to use either Suspend-to-RAM mode or Save-to-Disk mode.

Powering Up the Pen Tablet

Follow the procedure below to start the Stylistic LT C-500 pen tablet. Before you begin, confirm that the system is in the Off state. To do so, observe the Status display. If the Power icon is not visible in the Status display, the system is in the Off state or in Save-to-Disk mode and it is safe to perform this procedure. If the Power icon is visible (either blinking or on continuously), do not perform this procedure. See “System States” earlier in this chapter for details on operational modes represented by the Power icon.

1. Ensure that the battery pack in your pen tablet is sufficiently charged, or connect an external power source such as the AC adapter or auto adapter to your pen tablet. See “Status Display” in Chapter 1 to determine the percentage of charge represented by the Battery Gauge icon in the Status display.
2. Press the Suspend/Resume button to start the system.

After performing system initialization, the system starts the operating system installed on the hard disk drive. Once the operating system is running, you can use the system.

Shutting Down the System

Follow these steps to shut down and turn off your system:

Note: *Always use the following procedure unless your system has frozen up and will not allow normal shutdown. If you need to shut down after your system freezes up, click the recessed Shut Off button located to the right of the DC Input jack. **Do not use the Shut Off button as your normal means of powering down the system;** when the Shut Off button is used, all active data is lost.*

1. If system operation has been suspended, resume system operation. (See Table 1-1 and “Resuming System Operation” later in this chapter for details.)
2. Save your work and close all running programs.
3. Choose Shut Down from the Windows Start menu and carry out the Shut Down command. The system is now in the Off state.

Suspending System Operation

The Stylistic LT C-500 pen tablet allows you to suspend the system operation without closing programs or exiting the operating system. Use this feature to conserve battery power when a system shutdown is not practical or when the battery needs to be changed.

To suspend system operation:

1. Press the Suspend/Resume button, or carry out the Standby command from your operating system or power management program. (If your system is configured to suspend operation using Save-to-Disk mode, which is explained later in this procedure, a message is displayed while data is saved to your hard disk.)

Cautions

If you are replacing the battery pack, **wait until system is off or system operation is suspended and the power icon is flashing** before you remove the battery pack. Failure to do so could result in loss of your unsaved data.

The Power icon either flashes (Suspend-to-RAM) or is not displayed (Save-to-Disk) when system operation is suspended, depending on how your system is configured. At this point, programs that were running are stopped, active data is saved, and the system enters one of two different low-power states, or suspend modes, as explained in the following paragraphs.

2. Observe the Power icon in the Status display to determine which suspend mode your system is using.

- **Power icon is blinking:** *Suspend-to-RAM* mode
In this mode, active data is saved by maintaining power to RAM while most other system components are powered off. The Battery Gauge icon in the Status display indicates the battery charge level.
- **Power icon is not displayed:** *Save-to-Disk* mode
In this mode, active data is stored on the hard disk drive and power usage is reduced to the same level used in the Off state. When the system is in *Save-to-Disk* mode, the Battery Gauge icon is not visible in the Status display. In this mode, there is no danger of losing data if battery power is lost.

If you have successfully performed this procedure, system operation is now suspended. Refer to “Resuming System Operation” later in this chapter to resume system operation. Also, note the following with regard to suspending system operation:

Caution

- If the battery goes dead while the system is in Suspend-to-RAM mode, data loss could occur. If the system will be in Suspend-to-RAM mode for an extended period of time, be sure to have a fully charged battery installed.
- The system is supported by a bridge battery for approximately five minutes while the main battery is being replaced. Be sure to replace the main battery quickly or use the AC Adapter when replacing the battery.

- You can remove the battery pack while the system is in Suspend-to-RAM or Save-to-Disk modes in order to install a charged battery pack. To prevent losing unsaved data, wait until system operation has suspended before you remove the battery pack.
- Your system may be configured to suspend operation automatically after a period of inactivity.
- Your system may be configured to enter Save-to-Disk mode automatically after a period of time in Suspend-to-RAM mode.
- The system uses a small amount of battery power when in Suspend-to-RAM mode. Eventually, the battery will become fully discharged.

Note: *If you will not be using the system for an extended period of time, shut down the system rather than using Suspend-to-RAM mode.*

- If the battery pack charge drops to a Low-Battery Warning level while the system is running, the system will beep periodically. If this occurs, suspend system operation, shut down the system, or attach an external power source, such as the AC adapter, to the pen tablet.
- If the battery charge drops to a Critically Low level while the system is running, the system is forced into a pre-selected mode (Suspend-to-RAM or Save-to-Disk). If this occurs, you must either install a charged battery pack, or connect an appropriate external power source such as the AC adapter before you can resume system operation. (If the battery charge drops to a Critically Low level while the system is *in* Suspend-to-RAM mode, the system stays in Suspend-to-RAM mode until power is restored or totally dissipated.)
- Suspending system operation interrupts data communications; therefore, some programs may block the system from suspending to prevent an interruption.
- The suspend action of the Suspend/Resume button may be disabled to prevent accidental interruption. If this is the case, pressing the Suspend/Resume button will not suspend system operation as described here. (In this case, suspend mode can only be achieved using the system software). Contact your local help desk or reseller if your system configuration is not suitable.
- If your system is equipped with a PC Card that allows you to connect to a wired or wireless network, you may be logged off the network after a period of inactivity while system operation is suspended. Contact your network administrator or local help desk for details on log-off parameters for your network.

Resuming System Operation

To resume system operation, (from either Suspend-to-RAM or Save-to-Disk modes), press the Suspend/Resume button.

- From Suspend-to-RAM mode
Status lights indicate that the system state is changing. It may take up to a minute before the system returns to the On state and system operation resumes. Note that the display turns on shortly before the pen becomes active due to the power-up sequences observed by the system.
- From Save-to-Disk mode
Active data is read from the hard disk drive, and the system returns to the On

state after a short period of time.

Note that power to several system components must be restored before system operation resumes. Allow sufficient time for system operation to resume before attempting to use the system. If your system uses Save-to-Disk mode, it will take longer to resume operation as compared to using Suspend-to-RAM mode. Time is needed to read data from the hard disk drive.

- Use the system as you normally would once system operation resumes.

All programs resume at the point where execution stopped when system operation was suspended.

Using Hotpads

The Hotpad area consists of several pen-active “keys” on the right side of the system display that you can use to change several settings. The hotpads allow you to:

- Adjust the display and speaker settings
- Invoke right mouse button
- Invoke hovering capability
- Use as a numeric pad
- Use as a NumLock key

To use a hotpad key, tap directly on it with the pen. You can also press and hold the pen tip against the Volume and Brightness hotpad keys to automatically repeat the hotpad function. The location of each hotpad key is shown in Figure 2-1.

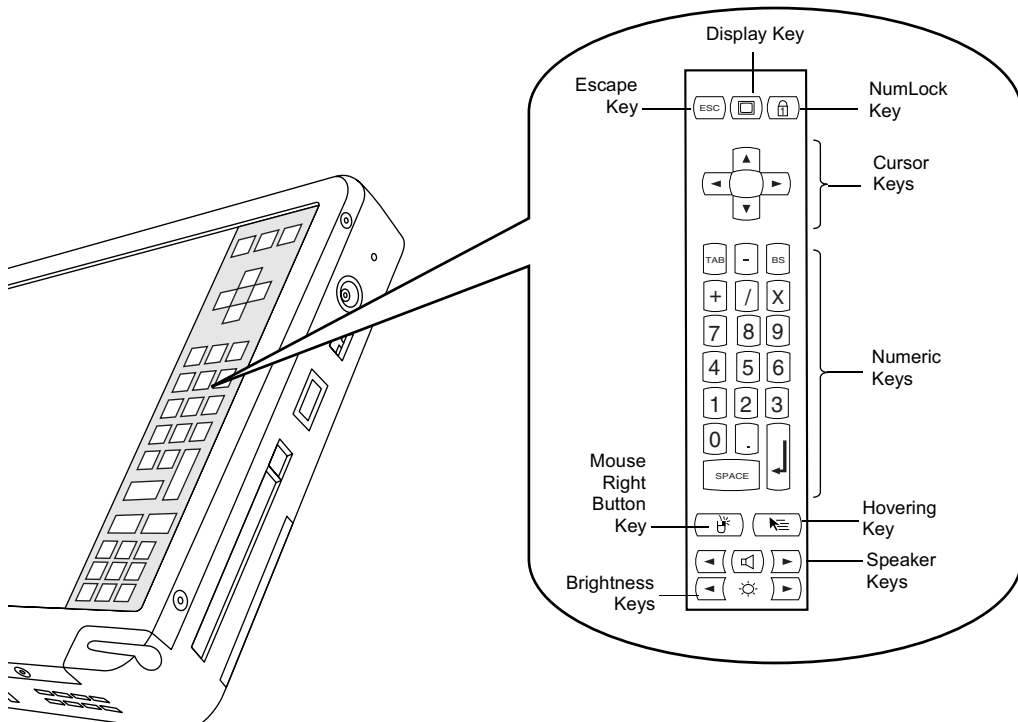

Figure 2-1 Stylistic Hotpad Arrays

A summary of each hotpad's function is given below.

Note: Equivalent key codes are included for applicable hotpad keys. These can be used when a keyboard is connected.

Table 2-2 Hotpad Keys











Icon	Name	Description
	Escape	Functions the same as the [Esc] key on a typical keyboard.
	Display Device	Each time the Display Device hotpad key is tapped, the display unit is switched (in the following order): LCD -> CRT -> both LCD and CRT -> LCD... External video is available from the docking station.
	NumLock	Acts in the same way as the NumLock key on the keyboard. (The default is Off).
	Cursor Control	Acts in the same way as the cursor keys on a keyboard. (Up, Down, Left, and Right).
	Numeric Keypad	Acts in the same way as the numeric keypad on a keyboard.
	Right Mouse Button	Switches the pen function from left mouse button to right mouse button emulation for a single mouse event after tapping the hotpad.

Table 2-2 Hotpad Keys

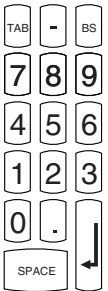
Icon	Name	Description
	Pen Hovering	Switches the hovering mode on or off. Throughout the hovering mode, the hovering status indicator is lit green. Refer to the section of this chapter entitled “Using Hovering Mode” for additional information.
	Speaker Volume Down	Lowers the speaker volume.
	Speaker Volume Up	Increases the speaker volume.
	Speaker Volume Mute	Toggles the speaker off and on.
	Brightness Down	Decreases the luminance of the display backlight. (Changes in brightness level can be monitored with the on-screen indicator)
	Brightness Up	Increases the luminance of the display backlight. (Changes in brightness level can be monitored with the on-screen indicator)

Using the Pen

You can use the Stylistic LT C-500 pen to generate and create electronic “ink”, to select items, and to navigate through programs on the pen tablet. The pen can be used like a two button mouse when used in conjunction with the right-mouse button hotpad. Programs which support handwriting recognition allow you to write characters directly on the screen with the pen and then translate your printed text into keyboard-style input.

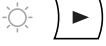
Caution

- Ensure that a screen protector is installed on the pen tablet screen before you use the pen. The warranty does not cover a screen that is scratched as a result of not using a screen protector.
- Use only the pen stylus provided with your pen tablet. Do not use substitutes that were not designed for the Stylistic LT C-500.

To toggle between using the pen for inking and using it as a mouse, click on the small pen icon in the system tray at the bottom right of the screen.

Here are some hints on using the pen like a two-button mouse on a desktop system:

- **To select an object**, tap the mouse tip on the object once. This functions like a mouse button click with the left mouse button.
- **To “double-click” an object**, tap twice on the object quickly.
- **To generate a “right mouse button single-click”**, tap on the hotpad icon once and then tap once on the display. To generate a **“right mouse button double click”**, tap on the hotpad icon once and then double tap on the display.
- **To move, or “drag”, an object on the screen**, place the pen tip directly over the object, then as you hold the pen tip against the screen, move the pen.

Calibrating the pen

Calibration of the pen adjusts the cursor position on the screen relative to the position of the pen tip. You calibrate the pen to adjust the distance error between where the pen actually touches the screen and where the system “thinks” the pen is touching. If the event you wish to invoke is not displayed under the pen tip when you use the pen, you should calibrate the pen.

Pen calibration may be required due to the following situations:

- The pen is being used for the first time.
- The previous user of the Stylistic LT C-500 pen tablet writes with the opposite hand or at a different pen angle.
- The system has been in use for some time and the pen has not been recalibrated.
- The original system image has been restored.

To Calibrate the Pen

1. Open the Control Panel from the Start | Settings menu, and double-tap the Pen Configuration icon. Select the Calibration property sheet, then click on Pen Calibration.
2. Position the Stylistic LT C-500 pen tablet as you normally would during use. Be sure to hold the pen at the angle that you regularly use. Touch the screen only with the pen tip; if you inadvertently touch the screen with your finger or hand during the calibration process, faulty calibration may result.
3. Perform the calibration steps according to the instructions on the screen. The calibration utility displays a cross-hair symbol in the middle and corners of the screen, one corner at a time. Hold the pen as you normally would while using the system and, as accurately as possible, tap the center of each crosshair as it is displayed.

A dialog box is displayed after you tap the last of the four cross-hair symbols. Tap the screen within 20 seconds if you wish to save your new calibration settings. If you don't tap the screen within 20 seconds, the default calibration settings will be used.

4. When the Verify New Pen Calibration Settings window appears, choose one of the following steps.
 - If you are satisfied that you tapped the cross-hairs accurately, tap Yes. The taps that you performed in step 3 are then used to calibrate the screen.
 - If you do not want to use the new calibration, tap No.
 - If you want to enter a new calibration, tap Recalibrate. The calibration instructions reappear.

If you have successfully performed the procedure above, the pen is now recalibrated, and you can use the system as you normally would.

Replacing the Pen

With use, the pen tip may become worn or may pick up foreign particles that can scratch the screen. A damaged or worn tip may not move freely, causing unpredictable results when using the pen. If your pen exhibits these problems, replace the pen by contacting your reseller.

Using Hovering Mode

Selecting the Pen Hovering icon on the Stylistic LT C-500 keypad provides the user with better cursor control. When the hovering option is enabled, the cursor can be positioned over an icon without activating it. This is useful when you are performing procedures that require accurate cursor positioning, such as when simulating mouse rollover, selecting a small icon, or beginning a paint session.

- To enable hovering, tap the Pen Hovering icon on the keypad. The Hovering system status indicator light illuminates green when hovering is selected.
- To disable hovering, tap the Pen Hovering icon again. The Hovering system indicator light is off when hovering is not selected.

Charging the Battery Pack

The Stylistic LT C-500 battery pack can be charged while it is installed in the pen tablet.

To do so:

1. Connect an AC adapter to the DC input connector on the pen tablet. The DC Input icon appears in the Status display. If the battery pack charge level is below 90%, the battery pack begins charging and the Charging icon appears in the Status display. If the battery pack charge is 90% or higher *when you connect* DC power, the battery pack will not charge, preventing overcharging the battery pack.
2. Look at the Battery Gauge icon in the Status display to determine the percent of charge in the battery pack. See “Status Display” in Chapter 1 of this manual for a description of the Battery Gauge icon.

As long as DC power *remains connected* to the pen tablet, the charging process continues until the battery pack charge reaches 100%. Charge times shown in Table 2-3 are for a fully discharged battery pack charging both while the pen tablet is and is not in use.

Table 2-3 Battery Pack Charging Time

Battery Pack Charge Level Reached	Approximate Charge Time (tablet not in use)	Approximate Charge Time (tablet in use)
90%	3 hours	6 hours*
100%	4 hours	8 hours*

* Actual charge time will be determined by the applications in use.

Also note the following with respect to charging the battery pack:

- You can use the system, suspend system operation, or shut down and turn off the system without interrupting the charging process; however, using the system while the battery pack is charging will cause the battery pack to charge at a slower rate, as noted in Table 2-3.
- As noted in the procedure above, the system will not begin charging the battery pack if the battery pack charge level is 90% or higher when the system is *initially connected* to external DC power. (This prevents the battery pack from being overcharged.)
- The Stylistic LT C-500 battery pack uses Lithium ion battery cells which have no “memory effect.” You do not need to discharge the battery pack before you begin charging.

Removing and Installing the Battery Pack

The battery pack can be removed from the pen tablet and swapped with a charged battery pack. The battery pack can then be charged in an external charger if one is available. To remove the battery pack from the pen tablet:

1. Choose one of the following:
 - If a charged battery pack is available, you can suspend system operation. A built-in “bridge” battery will maintain the system in Suspend-to-RAM mode for about 5 minutes while the battery pack is removed; this allows time for replacement with a charged battery pack.
 - If a charged battery pack is not available, save your work and close all running programs, then shut down the system or Save-to-Disk.
 - Plug in an external AC/DC power source.

2. Slide the spring-loaded battery release switch in the direction indicated in Figure 2-2.
3. While holding the switch, slide the battery pack away from the top of the system, as indicated in Figure 2-2.

If you are using an external battery charger, refer to the instructions provided with the battery charger.

To install the battery pack:

Orient the battery such that the grooves on the sides of the battery align with the slides inside of the battery tray. Slide the battery pack into the tray and press it firmly into the tray until it is seated. When it is properly seated, the battery release switch will automatically latch the battery pack into place.

Once the battery pack is installed, you can resume system operation or start your system and use the system normally.

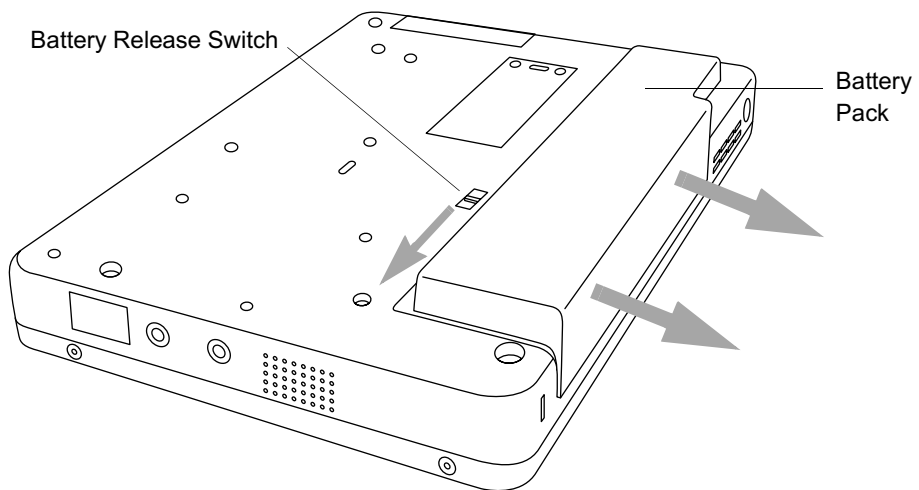

Figure 2-2 Removing the Battery Pack

Tips for Conserving Battery Power

You can extend the charge life of your battery pack by conserving battery power. A fully charged battery pack can run the system under normal use in most applications for approximately 2.5 hours*. Your results may vary depending on your application

and how the system is configured. Here are some suggestions to help you conserve battery power:

- Use an external power source such as the AC adapter to power the system when possible.
- Suspend system operation if you know that you won't be using the system for a while.
- Shut down the system if you won't be using the system for an extended period of time.
- Use power management timeouts (accessible through the BIOS setup) to help you conserve power automatically. Contact your reseller before modifying the BIOS.

* Battery life is dependent upon a number of factors: operating system, power settings, and applications or peripherals in use.

Operation of the Bridge Battery

When installed in the pen tablet, the battery pack provides power to some system components—even when the system is in the Off state. When the battery pack is removed, power is supplied to these components by a “bridge” battery that is built into the pen tablet.

The bridge battery is not designed for long-term operation (it will support a suspended system for between five and ten minutes). To maintain the bridge battery properly, observe the following measures:

Note: The system arrives with the bridge battery in a discharged state.

- To prevent draining the bridge battery, always store the pen tablet with a charged battery pack installed.
- If the bridge battery becomes drained, it takes approximately 11 hours for it to be fully recharged.
- The bridge battery charges from the AC Adapter when the adapter is connected and the system is in On or Off states or Suspend mode. It charges from the battery only when the system is in the On state.

Modem Connection

- Notes:**
- *The internal 56 Kbps LAN/modem module installed in the Stylistic LT C-500 pen tablet has actual maximum transfer rates of 53 Kbps (receive), 33.6 Kbps (send), and 14.4 Kbps (fax). Download rates are limited to 53 Kbps in the United States due to FCC restrictions.*
 - *The modem module is certified only in the following countries: United States, Canada, Japan, Belgium, Denmark, Finland, France, Germany, The Netherlands, Italy, Norway, Sweden, Switzerland, United Kingdom, Austria, Portugal, Ireland, Spain, and Greece.*
 - *The LAN portion of the internal LAN/modem module can only be used when the system is used with the optional mini-dock; there is no LAN port on the system itself.*

The Stylistic LT C-500 pen tablet is designed to accept a standard RJ-11 telephone plug. Connect the plug to the modem jack located on the right-hand side of the pen tablet, to the left of the DC Input jack (reference Figure 1-1). The telephone plug can be installed whether or not the pen tablet has power applied.

If you need assistance configuring the Stylistic LT C-500 pen tablet modem or LAN, contact your local help desk or your reseller.

PC Card Slot

The Stylistic LT C-500 pen tablet PC Card slot allows you to install a Type II PCMCIA CardBus card.

To install a PC card, position the side with the arrow facing up (i.e., when looking at the tablet's display side, the arrow on the card should be visible.) Slide the card into the PC Card slot, and press it firmly to ensure proper seating.

If you need assistance installing a PC Card in the Stylistic LT C-500 pen tablet, contact your local help desk or your reseller.

Compact Flash Slot

The compact flash memory slot allows you to add a flash module (CF Card) for compact, removable data storage.

To install a compact flash module,

1. Slide the Compact Flash slot cover in the direction indicated in Figure 2-3a. Once the tray is fully extended, the cover drops into a vertical position, as shown in Figure 2-3b.
2. With the arrow on the module label facing upwards, insert the compact flash module into the slot and push it in until it is firmly seated.
3. Swing the slot cover back into a horizontal position and push it into the system until it clicks in place.

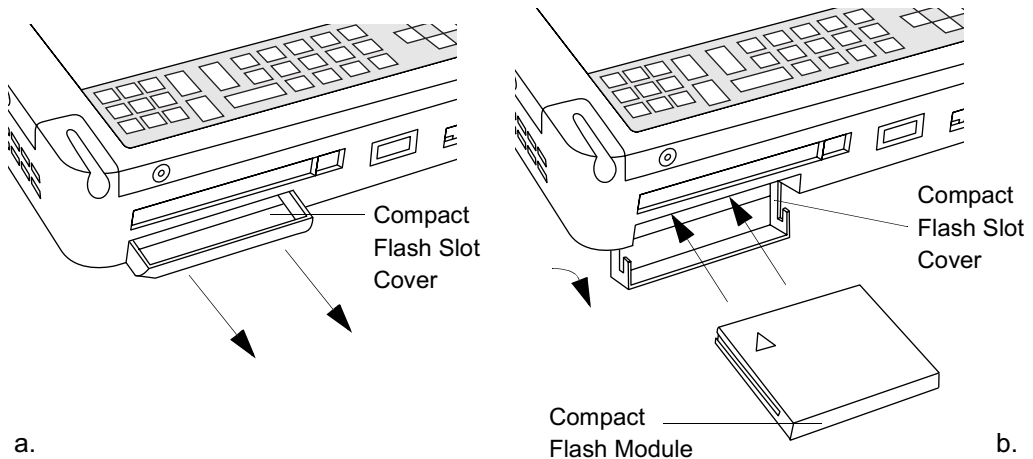

Figure 2-3 Installing a Compact Flash Module

To remove a compact flash module,

1. Slide the Compact Flash slot cover in the direction indicated in Figure 2-3a. Once the tray is fully extended, the cover drops into a vertical position, as shown in Figure 2-3b.
2. Pull the compact flash module out of the slot.
3. Swing the slot cover back into a horizontal position and push it into the system until it clicks in place.

Chapter 3

Care and Maintenance

This chapter gives you pointers on how to care for and maintain your Stylistic LT C-500 pen tablet.

Protecting the Display Screen

The Stylistic LT C-500 pen tablet is designed to provide you with years of service. Using a screen protector will help ensure that the screen remains as clear as possible. When installed, the screen protector becomes a durable, replaceable writing surface that protects the display screen from abrasion.

To obtain additional screen protectors use Fujitsu part number FMWSP11 (12-pack) when ordering. Additional information about installation is included with the screen protectors.

Caution

During normal use of the pen tablet, small particles from the environment can become embedded in the pen tip and scratch the screen. To prevent scratching the screen, ensure that a screen protector is installed before using your pen tablet. The warranty does not cover a screen that is scratched as a result of not using a screen protector.

To install a new screen protector on your pen tablet:

1. If a screen protector is already installed on the display screen, remove it before installing the new screen protector.

The screen protector is held onto the display screen surface by a thin strip of adhesive around the edges. A notch in one corner of the screen protector allows you to slide your fingernail under the screen protector for easy removal.

2. Clean the display by wiping the screen surface gently using a soft cotton cloth dampened with denatured alcohol. Ensure that all residue has been removed from the screen before applying a new screen protector.

Caution

The Stylistic LT C-500 pen tablet is **not waterproof**. Do not pour liquids on the system or wash it with a heavily soaked cloth.

3. Remove the protective coating from the adhesive side of the screen protector first.
4. Apply the screen protector to the display screen surface. When doing so, orient the screen protector with the adhesive side of the screen protector facing the display screen and the notched corner of the screen protector toward the lower left corner of the display screen.
5. **Apply pressure to the screen protector with your finger using a continuous wiping motion along the edges.** The adhesive sets completely within 48 hours. To ensure a good seal between the screen protector and the display, do not lift the screen protector from the display once it has been applied.
6. Remove the protective plastic cover from the face of the screen protector.
7. Clean any residue left behind by the protective coating from the exposed surface of the screen protector by wiping gently with a soft cotton cloth dampened with denatured alcohol. Wipe the screen protector with a soft dry cloth to remove any low-tack adhesive; this will help prevent the pen tip from squeaking.

The screen protector is now installed.

Storing the Stylistic LT C-500 Pen Tablet

Caution

Be sure not to store your Stylistic LT C-500 with the screen side down, otherwise damage to the display may occur.

Store the Stylistic LT C-500 pen tablet in the Off state with a fully charged battery pack installed. The Stylistic LT C-500 battery pack always provides power to some system components, even when the system is in the Off state. If the system is stored with the battery pack removed, these components are powered by the system's internal bridge battery. The bridge battery is not designed for extended use and will discharge in a short period of time; this could result in damage to the batteries. You can store the pen tablet in the Off state for about 30 days with a fully charged battery

pack installed. After this period, the battery pack should be recharged or replaced with a charged battery pack.

Avoiding Overheating

The Stylistic LT C-500 pen tablet monitors its internal temperature. As the internal temperature approaches the tolerable limits of heat-sensitive components, system functions are automatically limited or turned off to prevent damage.

To avoid overheating the pen tablet, do not obstruct the air vents on the top and bottom edges of the pen tablet.

Cleaning the Display Screen

To clean the pen tablet display screen, wipe the screen surface gently using a soft cotton cloth slightly dampened with water or denatured alcohol.

Caution

The Stylistic LT C-500 pen tablet is **not waterproof**. Do not pour liquids on the pen tablet or wash the pen tablet with a heavily soaked cloth.

Troubleshooting

Solutions to some common problems are described in the following sections. If you are experiencing a problem with your Stylistic LT C-500 pen tablet that you cannot solve by taking the actions described, contact your local help desk or your reseller for further assistance.

System Will Not Resume Operation

If the system will not resume operation after system operation has been suspended, check the following possible causes:

- The battery pack may either be defective, or discharged to the critically low level. When the battery pack reaches the critically low level, the system is forced into Suspend-to-RAM mode to avoid a total system power failure. To correct this problem, either connect an external power supply (such as the AC adapter), or install a charged battery pack in the pen tablet.
- The system may be at the critical thermal limit. To avoid damage to heat-sensitive components, the system enters Suspend-to-RAM mode when it gets too hot. System operation cannot be resumed until the pen tablet cools off to a tolerable temperature. Move the pen tablet to a cooler location.

Display Screen Is Blank or Difficult to Read

If the display screen on your Stylistic LT C-500 pen tablet appears blank or is unreadable, confirm that the system is running (the Power icon is displayed continuously on the Status display), and check the following:

- The system brightness may be set too low, causing the screen to appear too dark. Use the brightness hotpad to adjust the screen brightness.
- An external monitor may be selected. Tap on the Display Select hotpad to determine whether the pen tablet display screen is selected.
- The video timeout may have expired. Tap on the display screen to reactivate the display. Note that this is a normal, power-saving feature.

Cursor Is Not Tracking Pen

If the cursor on the screen appears to be misaligned with the pen or is not accurately tracking the pen, calibrate the pen. See “Calibrating the Pen” in Chapter 2 for details.

Infrared Data Transfer Is Not Working

If you are experiencing problems transferring data over the system's infrared interface, note the following:

- Can the IrDA port on the pen tablet "see" the IrDA port on the other device? A direct line-of-sight path must exist between the IrDA port on the pen tablet and the IrDA port on the other device.
- The distance between the two devices must not be more than approximately 3 feet or 1 meter.
- The viewing angle from the IrDA port on the pen tablet must not be more than 15 degrees from a center line between the IrDA port on the pen tablet and the IrDA port on the other device.
- The device with which you are trying to communicate must be compliant with the IrDA Standard Revision 1.1 (or 1.0).

Pen Tablet Is Not Responding to the Pen

If your pen tablet is not responding to the pen, connect an external keyboard to the system to see if it responds to keyboard commands. If the system doesn't respond to the keyboard, the application or system may have crashed, and it may be necessary to reset the system.

Audio Volume Too Low

If the audio volume on your pen tablet speaker or external headphones is too low, check the following:

- Ensure that the speaker (or headphone output if using headphones) is enabled. To do so, tap the Speaker Mute hotpad. The system beeps when the speaker or headphone output is turned on using the hotpad.
- Ensure that the volume level set with the Volume hotpads is set to an audible level.
- Ensure that the mute box in the system volume control (accessible from the system tray) is not set.
- Ensure that any volume control in your audio software is set to an audible level.

Configuring Peripherals Interfaces

Certain peripheral devices can be disabled during the BIOS Setup. If the peripheral interface you want to use does not appear to be working with your peripheral device, ensure that it is enabled in the BIOS. Contact your local help desk or reseller if you need assistance using BIOS Setup.

Appendix A

Stylistic LT C-500 Hardware Specifications

The following table provides general hardware specifications of the Stylistic LT C-500 by category.

Stylistic LT C-500 Specifications	
Physical Specifications	
Dimensions	9.45" w x 6.3" d x 1.1" h (240mm x 160mm x 28mm)
Weight	2.75 lb. (1.24 kg) with 6 cell battery
Processing Specifications	
CPU	Celeron 500 MHz
Chip set	Intel 440MX - 100
Memory/Storage Specifications	
Main RAM	Depending upon the system configuration, a 64MB, 128MB, or 256MB module is installed on board.
L1 cache (CPU)	32 KB
L2 cache (CPU)	128 KB
BIOS ROM	512 KB (flash ROM with boot block)
Hard disk drive	<ul style="list-style-type: none">• Removable 2.5" HDD• 6 GB IDE HDD
Input/Output Specifications	
Digitizer	<ul style="list-style-type: none">• Resistive, with palm rejection
VRAM	<ul style="list-style-type: none">• 2.5 MB VRAM
Display	<ul style="list-style-type: none">• 8.4" TFT SVGA (800 x 600 dot)• 256K colors• Brightness: 8 levels

Stylistic LT C-500 Specifications (Continued)

Interface Specifications

PC Card Slot	<ul style="list-style-type: none"> • One Type-I or Type-II • PCMCIA CardBus version 3.0
Compact Flash Card Slot	<ul style="list-style-type: none"> • Standard 50-pin compact flash card connector
Integrated Interfaces	<ul style="list-style-type: none"> • RJ-11 (modem) • USB 1.0 • DC-In • Expansion connector
Modem/LAN	<p>Internal combination Modem/LAN module</p> <ul style="list-style-type: none"> • LAN part: 10BaseT/100BaseT (dock only) • Modem part: 56 Kbps (V.90), 53 Kbps receive/33.6 Kbps send/14.4 Kbps fax
Infrared	IrDA version 1.1 (FIR, 4Mbps)
Audio	<ul style="list-style-type: none"> • Sound Function + AC'97 codec • Sound Blaster Pro-compatible • Internal microphone and speaker • Microphone and headphone jacks
High-Usage Docking Contacts	<ul style="list-style-type: none"> • DC-In
User Controls	<ul style="list-style-type: none"> • Hotpads: escape, volume, numlock, arrow keys, display, brightness, right button, hovering, numeric keypad • Suspend/Resume button • Reset button (Power Off switch)
Status Indicators (LEDs)	<ul style="list-style-type: none"> • Power • Charge/DC-In • Battery level • HDD • Hovering

Stylistic LT C-500 Specifications (Continued)	
Power Specifications	
Main Battery	<ul style="list-style-type: none"> • 6-cell • Removable, Lithium ion • 10.8 V @ 3100 mAH • Warm-swappable • Recharge Time: Suspend/Off: 3 hours (90%), 5 hours (100%) Operating (slow charge): 6 hours (100%) • Suspend Life: Minimum 5 days Off State: Approximately 30 days from full charge
Environmental Specifications	
Temperature	Operating: 0° - 40° C (32° - 104° F) Non-operational: -20° - 60° C (-4° - 140° F)
Humidity	Operating: 20 - 80% non-condensing Non-operating: 20 - 80% non-condensing
Agency Approval Specifications	
Emissions	<ul style="list-style-type: none"> • EN55022, Class B:1995 • FCC Part 15, Class B
Immunity	<ul style="list-style-type: none"> • EN61000-4-2:1995 • EN61000-4-3:1995 • EN61000-4-4:1995
Safety	<ul style="list-style-type: none"> • USL/CNL: UL1950, 3rd Ed. • TUV T-Mark: EN60950
Modem	<ul style="list-style-type: none"> • FCC Part 68, IC CS03
Additional Specifications	
Operating systems	Windows 98, Windows 2000

Digitizer Technology Notice

Additional Display Information

The display for your pen tablet incorporates a breakthrough digitizer technology that dramatically improves outdoor viewability. Compared to traditional outdoor displays, the new display excels in providing superior visibility in full sunlight, and a clear, bright picture indoors, in low light conditions, or at night.

This new technology involves the use of a liquid between the digitizer layers to minimize light refraction and reduce glare. As a result of this technology, users may notice the appearance of tiny air bubbles which are caused by changes in pressure (such as that experienced in an airplane). These tiny bubbles are temporary and do not affect system performance or usability. The digitizer functions normally when the air bubbles are present.

The air bubbles are formed when the liquid vaporizes due to pressure change. When the pen tablet is returned to normal use conditions, the tiny air bubbles are absorbed back into the liquid after a short amount of time.

If these air bubbles are visually distracting, or if they form a larger bubble, gently rub the screen with a soft cotton cloth in a circular motion, similar to cleaning the screen of fingerprint oil.

Appendix C

Agency Notices

UL Notices

Cautions

- Changes or modifications not expressly approved by Fujitsu PC Corp. could void this user's authority to operate the equipment.
- This unit requires an AC Adapter to operate. Use only UL Listed "Class 2" adapters with an output rating of 16 Vdc, 3.36 A. AC Adapter output polarity:



- To reduce the risk of fire, use only No. 26 AWG or larger telecommunication line cord.
- For a spare battery pack, order only Fujitsu Model **FMW43BP2**.
- To charge the battery pack **FMW43BP2** externally, use only a Stylistic external battery charger model **FMW51BC1**.
- There is a danger of explosion if the Lithium (CMOS) battery is incorrectly replaced. Replace only with the same or equivalent type recommended by the manufacturer. Dispose of used batteries according to manufacturer's instruction.

Warnings

(For Authorized Repair Technicians only:)

- For continued protection against the risk of fire, replace fuse only with the same type and rating of fuse.

FCC Notices

This equipment has been tested and found to comply with the limits for a Class B digital device, pursuant to Part 15 of the FCC rules.

Changes or modifications not expressly approved by Fujitsu PC Corporation, could void the user's authority to operate the equipment.

Notice to Users of Radios and Television

These limits are designed to provide reasonable protection against harmful interference in a residential installation. This equipment generates, uses, and can radiate radio frequency energy and, if not installed and used in accordance with the instructions, may cause harmful interference to radio communications. However, there is no guarantee that interference will not occur in a particular installation. If the equipment does cause harmful interference to radio or television reception, which can be determined by turning the equipment off and on, the user is encouraged to try to correct the interference by one or more of the following measures:

- Reorient or relocate the receiving antenna.
- Increase the separation between the equipment and receiver.
- Connect the equipment into an outlet that is on a different circuit than the receiver.
- Consult the dealer or an experienced radio/TV technician for help.

Shielded interconnect cables must be employed with this equipment to ensure compliance with the pertinent RF emissions limits governing this device.

Caution

When using your modem equipment, basic safety precautions should always be followed to reduce the risk of fire, electric shock, and injury to persons, including the following:

- Do not use this product near water (for example, near a bath tub, wash bowl, kitchen sink or laundry tub, in a wet basement or near a swimming pool).
- Avoid using a modem during an electrical storm. There may be a remote risk of electric shock from lightning.
- Do not use the modem to report a gas leak while in the vicinity of the leak.

Notice to Users of the US Telephone Network

The Stylistic LT C-500 pen tablet is supplied with an internal modem which complies with Part 68 of the FCC rules. On the pen tablet is a label that contains the FCC Registration Number and Ringer Equivalence Number (REN) of this system, along with other information. If requested, users must provide their telephone company with the following information:

- The telephone number to which the pen tablet is connected

- The Ringer Equivalence Number (REN) for this equipment
- The information that the system requires a standard modular jack type USOC RJ-11C which is FCC Part 68-compliant
- The FCC Registration Number

This equipment is designed to be connected to the telephone network or premises wiring using a standard modular jack type USOC RJ-11C which is FCC Part 68-compliant.

The REN is used to determine the number of devices you may connect to your telephone line and still have all those devices ring when your number is called. Too many devices on one line may result in failure to ring in response to an incoming call. In most, but not all, areas, the sum of all of the devices should not exceed five (5). To be certain of the number of devices you may connect to your line, as determined by the RENs, contact your local telephone company.

If this equipment causes harm to the telephone network, your telephone company may discontinue your service temporarily. If possible, they will notify you in advance. If advance notice is not practical, they will notify you as soon as possible. You will also be advised of your right to file a complaint with the FCC.

This fax modem also complies with fax branding requirements per FCC Part 68.

If you experience trouble with this equipment, please contact your support representative.

Your telephone company will probably ask you to disconnect this equipment from the telephone network until the problem is corrected and you are sure that the equipment is not malfunctioning.

This equipment may not be used on coin service telephones provided by your telephone company. Connection to party lines is subject to state tariffs. Contact your state's public utility commission, public services commission, or corporation commission for more information.

FCC rules prohibit the use of non-hearing aid compatible telephones in the following locations or applications:

- All public or semipublic coin-operated or credit card telephones.
- Elevators, highways, tunnels, (automobile, subway, railroad, or pedestrian) where a person with impaired hearing might be isolated in an emergency.
- Places where telephones are specifically installed to alert emergency authorities

such as fire, police, or medical assistance personnel.

- Hospital rooms, residential health care facilities, convalescent homes, and prisons.
- Workstations for the hearing impaired.
- Hotel, motel, or apartment lobbies.
- Stores where telephones are used by patrons to order merchandise.
- Public transportation terminals where telephones are used to call taxis or to reserve lodging or rental cars.
- In hotel and motel rooms at least ten percent of the rooms must contain hearing aid compatible telephones which will be provided to hearing impaired customers on request.

DOC (Industry Canada) Compliance Notices

This digital apparatus does not exceed the Class B limits for radio noise emissions from digital apparatus as set forth in the radio interference regulations of the Canadian Department of Communications.

Le présent appareil numérique n'émet pas de bruits radioélectriques dépassant les limites applicables aux appareils numériques de classe B prescrites dans le règlement sur le brouillage radioélectrique édicté par le Ministère des Communications du Canada.

Notice to Users of Radios and Television

This Class B digital apparatus meets all requirements of the Canadian Interference-Causing Equipment regulations.

Cet appareil numérique de la classe B respecte toutes les exigences du règlement sur le matériel brouilleur du Canada.

Notice to Users of the Canadian Telephone Network

The Canadian Industry Canada label identifies certified equipment. This certification means that the equipment meets certain telecommunications network protective, operational, and safety requirements. The Department does not guarantee the equipment will operate to the user's satisfaction.

Repairs to telecommunication equipment should be made by a Canadian authorized maintenance facility. Any repairs or alterations not expressly approved by Fujitsu PC Corp. or any equipment failures may give the telecommunications company cause to request the user to disconnect the equipment from the telephone line.

The connecting arrangement code for this equipment is CA11A.

The Load Number is 0.2.

The Load Number assigned to each telephone terminal device denotes the percentage of the total load to be connected to a telephone loop or circuit to be used by the device to prevent overloading. The termination on a loop may consist of any combination of devices such that the total of the load numbers of all devices does not exceed 100.

Caution

For safety, users should ensure that the electrical ground of the power utility, the telephone lines, and the metallic water pipes are connected together. Users should **not** attempt to make such connections themselves but should contact the appropriate electric inspection authority or electrician. This may be particularly important in rural areas.

Avis Aux Utilisateurs Du Réseau Téléphonique Canadien

L'étiquette canadienne Industrie Canada identifie l'équipement certifié. Cette certification signifie que l'équipement satisfait certaines normes de protection, d'exploitation et de sécurité des réseaux de télécommunications. Le département ne garantit pas le fonctionnement de l'équipement à la satisfaction de l'utilisateur.

Caution

Certaines mesures de sécurité doivent être prises pendant l'utilisation de matériel modem afin de réduire les risques d'incendie, de choc électrique et de blessures. En voici quelquesunes:

- Ne pas utiliser l'appareil près de l'eau, p.ex., près d'une baignoire, d'un lavabo, d'un évier de cuisine, d'un bac à laver, dans un sous-sol humide ou près d'une piscine.
- Éviter d'utiliser le modem (sauf s'il s'agit d'un appareil sans fil) pendant un orage électrique. Ceci peut présenter un risque de choc électrique causé par la foudre.
- Ne pas utiliser l'appareil modem pour signaler une fuite de gaz s'il est situé près de la fuite.

Le Stylistic LT C-500 possède un modem interne conforme aux normes de certification d'Industrie Canada pour protéger les réseaux de télécommunications et satisfaire aux normes de sécurité. Avant de connecter cet équipement à une ligne

téléphonique, l'utilisateur doit vérifier s'il est permis de connecter cet équipement aux installations de télécommunications locales. L'utilisateur est averti que même la conformité aux normes de certification ne peut dans certains cas empêcher la dégradation du service.

Les réparations de l'équipement de télécommunications doivent être effectuées par un service de maintenance agréé au Canada. Toute réparation ou modification, qui n'est pas expressément approuvée par Fujitsu PC Corp., ou toute défaillance de l'équipement peut entraîner la compagnie de télécommunications à exiger que l'utilisateur déconnecte l'équipement de la ligne téléphonique.

Le code d'arrangement de connexion de cet équipement est CA11A.

Le numéro de charge est 0.2.

Le numéro de charge assigné à chaque terminal téléphonique indique le pourcentage de la charge totale pouvant être connecté à une boucle ou à un circuit téléphonique, utilisé par ce périphérique afin de prévenir toute surcharge. La terminaison d'une boucle peut être constituée de n'importe quelle combinaison de périphériques de sorte que le total de numéros de charge de tous les périphériques n'excède pas 100.

Avertissement

Pour assurer la sécurité, les utilisateurs doivent vérifier que la prise de terre du service d'électricité, les lignes téléphoniques et les conduites d'eau métalliques sont connectées ensemble. Les utilisateurs NE doivent PAS tenter d'établir ces connexions eux-mêmes, mais doivent contacter les services d'inspection d'installations électriques appropriés ou un électricien. Ceci peut être particulièrement important en régions rurales.

Index

A

- air flow vents, 4, 6
- audio volume too low, 35
- auto adapter, 2

B

- battery charger, external, 2
- battery gauge, 25
- battery gauge icon, 17
- battery icon, 8, 12
- battery pack, 2
 - charging, 25
 - charging times, 26
 - critically low level, 18
 - low-battery warning, 18
 - no memory effect, 26
 - overcharge protection, 25
 - removing and installing, 26, 27
 - storing in system unit, 32
 - will not begin charging, 26
- battery power
 - conserving, 27
 - used in suspend-to-RAM mode, 17
- battery release switch, 12
- battery switch, 5
- bridge battery, 28
- brightness, 20

C

- calibrating the pen, 23
- care and maintenance, 31
- Charge/DC input icon, 7
- charge-only cradle, 2
- charging the battery pack, 25
- cleaning the display screen, 33
- compact flash module
 - installing, 30
 - removing, 30
- compact flash slot, 5, 30

- configuring peripherals interface, 36
- connectors and peripheral interfaces, 9
- conserving battery power, 27
- critically low battery level, 18
- cursor
 - not tracking pen, 34

D

- DC adapter, 2
- DC input connector, 10
- DC power connector, 4
- display
 - screen is blank, 34
 - screen, cleaning, 33

E

- external battery charger, 2
- external floppy disk drive, 2

F

- FCC Notices, 43
- folding deskstand, 2

H

- hard disk drive access icon, 8
- headphone, 6
- headphone jack, 10
- high-usage metal contacts, 11
- holsters, 2
- hotpads, 4, 20
- hotpads, using, 20
- hovering mode, 25
 - disabling, 25
- hovering mode icon, 8

- I**
 - idle state, 13
 - infrared data transfer not working, 35
 - infrared keyboard, 2
 - infrared keyboard port, 3, 11
 - interfaces
 - connectors and peripherals, 9
 - internal LAN/modem, 1
 - IrDA port, 5, 11
- K**
 - Kensington lock, 5
 - keys
 - brightness, 22
 - cursor control, 21
 - display device, 21
 - escape, 21
 - numeric keypad, 21
 - NumLock, 21
 - pen hovering, 22
 - right mouse, 21
 - speaker volume, 22
- L**
 - low-battery warning, 18
- M**
 - memory cover, 5
 - microphone, 4
 - microphone jack, 6, 10
 - mini-dock, 2
 - mini-dock connector
 - connector, 11
 - mini-dock port, 11
 - mobile USB keyboard, 2
 - Modem
 - connection, 29
 - port, 4
 - modem, 11
- O**
 - Off state, 14, 16
 - optional accessories, 2
 - overheating, avoiding, 33
- P**
 - PC Card
 - slot, 4, 29
 - PC Card slot, 10
 - pen, 4
 - not responding, 35
 - replacing, 25
 - using, 23
 - peripheral connectors, 10
 - portfolio case, 2
 - power icon, 7, 14
 - blinking, 14, 17
 - not displayed, 14
 - power usage, 13
 - problems, solving, 34
 - protecting the display screen, 31
- R**
 - removable battery pack, 5
 - resuming system operation, 18, 34
- S**
 - Save-to-Disk mode, 13, 16, 17, 18
 - screen protectors, 2
 - Shut Off button, 4
 - shutdown button, 12
 - shutting down the system, 16
 - slip case, 2
 - solving problems, 34
 - speaker, 6
 - status display, 6
 - battery icon, 8
 - Charge/DC input icon, 7
 - hard disk drive access icon, 8
 - hovering mode icon, 8
 - icons, 7
 - power icon, blinking, 14
 - power icon, system states indicated by, 7, 14
 - storing the system unit, 32
 - Stylistic LT C-500

- care and maintenance, 31
- features, 3, 5
- items included with, 1
- storing, 32
- using, 13

Stylistic LT C-500 Specifications

- additional, 39
- agency approval, 39
- environmental, 39
- input/output, 37, 41
- interface, 38
- memory/storage, 37, 41
- physical, 37, 41
- power, 39
- processing, 37, 41

Stylistic Pen, 2

suspend mode, determining, 17

Suspend/Resume

- button, 5
- disabled, 18

suspend/resume button, 12

suspending system operation, 16

Suspend-to-RAM, 13

- mode, 17, 18

system interface port, 11

system states, 13, 14

- Idle state, 13
- Off state, 14
- On state, 13
- Save-to-Disk, 13
- Suspend-to-RAM, 13

system status LEDs, 3

system will not resume operation, 34

T

- troubleshooting, 34
- turning off the system, 16

U

- Universal Serial Bus, 4
- USB Port, 4, 10
- using the pen, 23
- using the Stylistic LT C-500, 13

W

- Windows 2000, 1
- Windows 98, 1

